

Physics II

Chapters 18 & 19

Winter 2017

IMPORTANT: Except for multiple-choice questions, you will receive no credit if you show only an answer, even if the answer is correct. Always show in the space on your answer sheet some sketches, words, or equations which clearly justify your answer. Show the equations you use and the values substituted into them whenever equations are necessary. If you go from a formula directly to an answer without showing the values used, you will lose points. Points will also be deducted for missing or erroneous units.

Each individual answer is weighted roughly evenly throughout the exam.

Name _____

- How much current flows through a 60 W light bulb that is subject to a 120 V potential difference?
 - 12 A
 - 2 A
 - 0.5 A
 - 7200 A
- How much energy is supplied to a 100 W light bulb in 60 s?
 - 0.6 J
 - 1.7 J
 - 6000 J
 - 0.0017 J
- An intrepid student measures the current that goes through a resistor and finds that it is 2 A. The same student also measures the potential difference between the two ends of the resistor and finds it to be 12 V. How much resistance does the resistor have?
 - 6 Ω
 - 0.17 Ω
 - 24 Ω
 - 48 Ω
- A steady current of 5 A is passing through a 20 Ω electric heater. At what rate is energy being supplied to this heater?
 - 4 W
 - 100 W
 - 500 W
 - 2000 W
- A 4 Ω , a 5 Ω , and a 6 Ω resistor are connected in series to a 30 V battery. The current that flows through this circuit is
 - 2 A.
 - 5 A.
 - 6 A.
 - 7.5 A.
- When a 120 V voltage is applied to eight lamps connected in series a current of 0.3 A flows through each lamp. The resistance of each individual lamp is
 - 15 Ω

- 50 Ω
- 400 Ω
- 3200 Ω

- The equivalent resistance of a 5 Ω and a 10 Ω resistor connected in parallel is
 - 2 Ω .
 - 3.3 Ω .
 - 7.5 Ω .
 - 15 Ω .

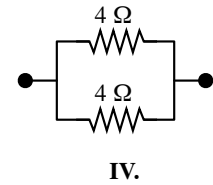
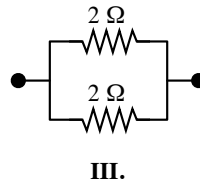
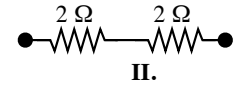
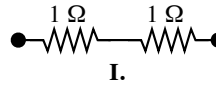

- Which two arrangements of resistors shown above have the same resistance between the terminals (the black dots)?
 - I and II
 - I and IV
 - II and III
 - II and IV
 - III and IV

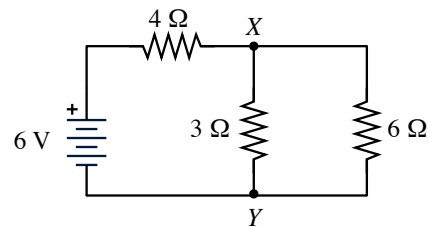

- In the circuit shown above, what is the value of the potential difference between points X and Y?
 - 1 V
 - 2 V
 - 3 V

- (d) 4 V
- (e) 6 V

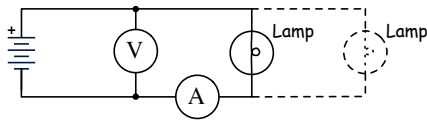

10. A lamp, a voltmeter V, an ammeter A, and a power supply are connected as shown above. The ammeter, which has no resistance, measures the amount of electric current flowing through it, and the voltmeter measures the difference in potential between its two points of contact with the circuit. Connecting another lamp in parallel with the first lamp as shown by the dashed lines would

- (a) increase the ammeter reading.
- (b) decrease the ammeter reading.
- (c) increase the voltmeter reading.
- (d) decrease the voltmeter reading.
- (e) produce no change in either meter reading.

11. The product

$$2 \text{ Amps} \times 2 \text{ volts} \times 2 \text{ seconds}$$

is equal to

- (a) 8 Coulombs.
- (b) 8 Newtons.
- (c) 8 Joules.
- (d) 8 newton-amperes.
- (e) 8 maids-a-milking.

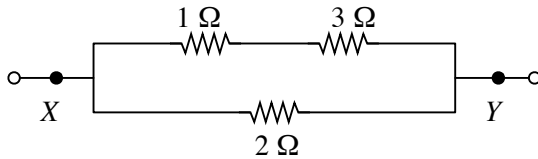

12. The electrical resistance of the part of the circuit shown between points X and Y is

- (a) $1\frac{1}{3}\Omega$
- (b) 2Ω
- (c) $2\frac{3}{4}\Omega$

- (d) 4Ω
- (e) 6Ω

13. A certain coffeepot draws 4.0 A of current when it is operated on 120 V household lines. If electrical energy costs 10 cents per kilowatt-hour, how much does it cost to operate the coffee pot for 2 hours?

- (a) 2.4 ¢
- (b) 4.8 ¢
- (c) 8.0 ¢
- (d) 9.6 ¢
- (e) 16 ¢

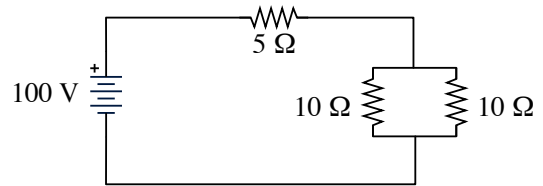

14. How much current flows through the 5 Ω resistor in the circuit shown above?

- (a) 40 A
- (b) 25 A
- (c) 20 A
- (d) 10 A
- (e) 4 A

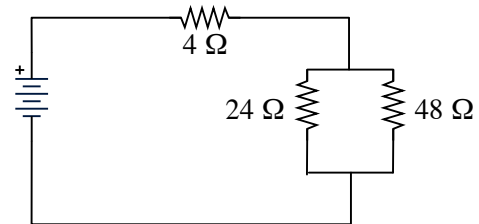

15. In the circuit shown above, the equivalent resistance of the three resistors is

- (a) 10.5Ω
- (b) 15Ω
- (c) 20Ω
- (d) 50Ω
- (e) 115Ω

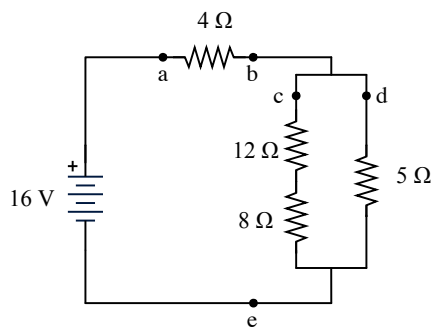

1. Refer to the resistor circuit shown above for the following questions.

- (a) Find the equivalent resistance of all the resistors in the circuit shown above.

- (b) Find the amount of current that flows through the $4\ \Omega$ resistor.

- (c) Find the potential difference between the ends of the $5\ \Omega$ resistor.

- (d) If the $5\ \Omega$ resistor is removed from the circuit above, the current in the $4\ \Omega$ resistor will

- i. increase.
- ii. decrease.
- iii. remain the same.

- (e) How does the current flowing through the $8\ \Omega$ resistor compare to the current flowing through the $5\ \Omega$ resistor?

- i. It is greater.
- ii. It is smaller.
- iii. It is equal to the current through the $5\ \Omega$ resistor.

- (f) Compare the current at point c with the current at point e. Which point has the larger current?

- i. Point c
- ii. Point e
- iii. Neither, they are the same. Current travels in one direction around the circuit.
- iv. Neither, they are the same. Currents travel in two directions around the circuit.

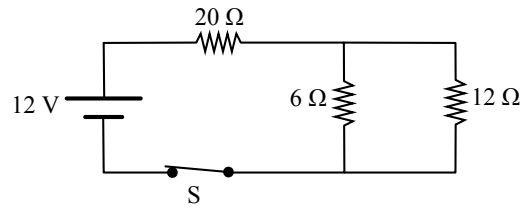

2. The circuit above contains a battery with negligible internal resistance, a closed switch S, and three resistors.

(a)

i. Rank the currents in the three resistors from greatest to least, with number 1 being greatest. If two resistors have the same current, give them the same ranking.

_____ I_{20} _____ I_6 _____ I_{12}

ii. Justify your answers.

(b)

i. Rank the voltages across the three resistors from greatest to least, with number 1 being greatest. If two resistors have the same voltage across them, give them the same ranking.

_____ V_{20} _____ V_6 _____ V_{12}

ii. Justify your answers.

(c) Calculate the equivalent resistance of the circuit.

(d) Calculate the current passing through the 12 Ω resistor.

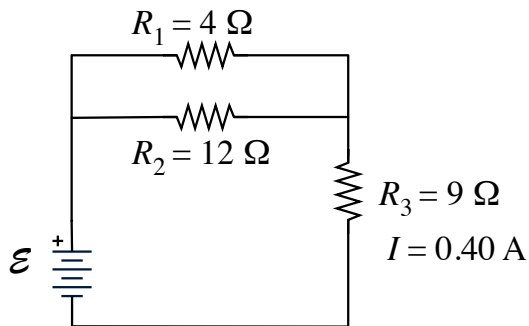

3. Three resistors are arranged in a circuit as shown above. The battery has an unknown but constant emf \mathcal{E} and a negligible internal resistance.

(a) Determine the equivalent resistance of the three resistors.

The current I in resistor R_3 is 0.40 Ampere.

(b) Determine the emf \mathcal{E} of the battery.

(c) Determine the potential difference across resistor R_1 .

(d) Determine the amount of charge that passes through resistor R_1 in one minute.

(e) Determine the amount of energy that is lost from the current to R_1 as heat in one minute.
